

VERTICAL CROSS SECTIONS

STRIKE JAMB DETAIL ABOVE & BELOW MAGNET

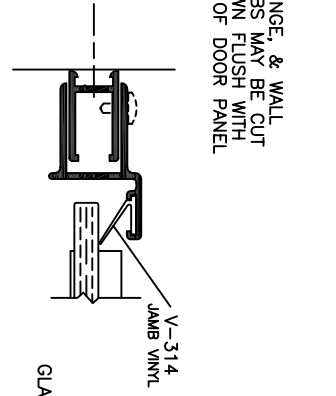

DOOR GLASS DETAIL

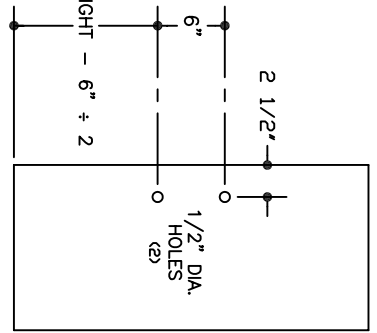

- NOTES:
1. The SC-4033 strike jamb magnet (4" long) should be centered in the jamb with V-314 jamb seal vinyl above and below it (see detail).
 - * 2. Application of tolerances may affect glass and horizontal frame member sizes.

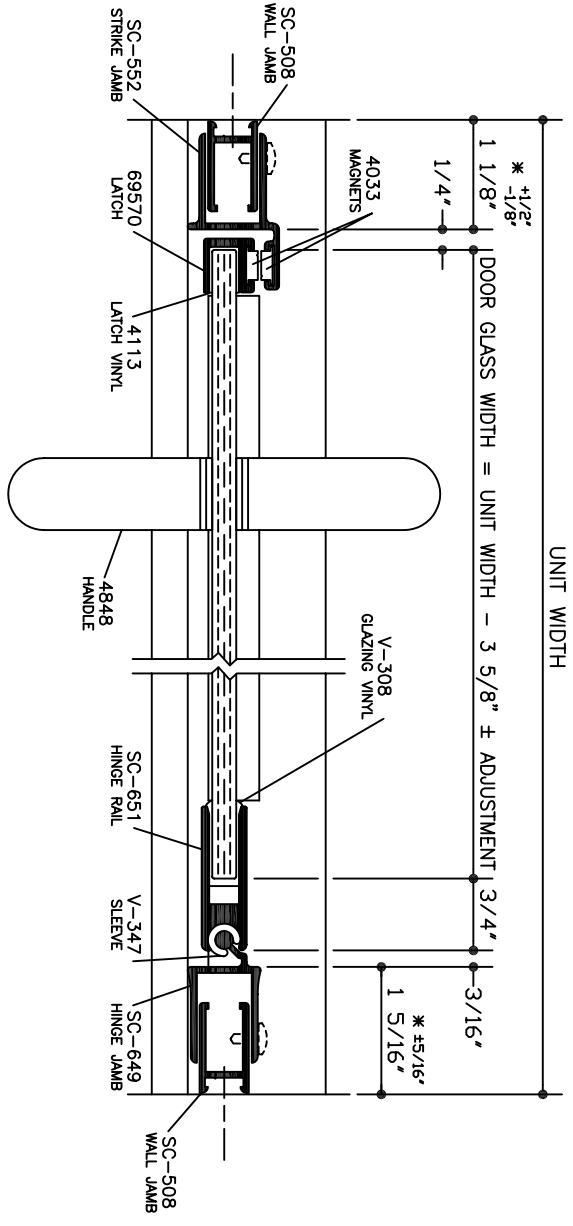

HORIZONTAL CROSS SECTION

NOTE: Glazing material for all KD units and Glazed units must conform to Ansi Z97.1 and CPSC Standard 16 CFC 1201 Category I and II.

EPH-NOO-06220
DATE: 3-16-05

SERIES

300CV

FRAMELESS CONTINUOUS HINGE

ALUMAX
BATH ENCLOSURES

a product of ALCOA
PO Box 40 - Magnolia, AR 71754-0040 - (870) 234-4260
www.alumaxbath.com