



ALUMAX

BATH ENCLOSURES

An Alcoa Company ®

Tel: 800-643-1514

Fax: 870-234-3181

www.alumaxbath.com

390cv CONTINUOUS HINGE FRAMELESS DOOR KIT

STIKSTALL INSTRUCTION SUPPLEMENT

This Alumax 390cv Continuous Hinge door panel kit is designed to be installed in our StikStall framework with an in-line panel (391), a return panel (392), an in-line and a return panel (393), a neo-angle unit (394), or between two in-line panels (395).

To ensure correct installation, this instruction supplement (packed with a glazed or KD door panel kit) is designed to be used with a StikStall Installation Instruction sheet (391, 392, 393, 394, 395) that will be packaged with the corresponding StikStall frame kit. Each step in the primary instruction sheet will indicate whether it applies to all door types or if this supplement should be used.

390cv PARTS LIST

- *A. 1 Glazed Door Panel
- *B. 1 Strike Jamb with Magnet
- *C. 2 Snap-in Fillers
- *D. 6 #8 x 1/4" Truss Head Screws
- *E. 1 Handle Vinyl
- *F. 1 Latch
- *G. 2 Tubular Handles
- *H. 4 Plastic Washers
- *J. 2 Plastic Bushings
- *K. 2 Cone Head Bolts
- *L. 2 Set Screws
- *M. 1 Deflector

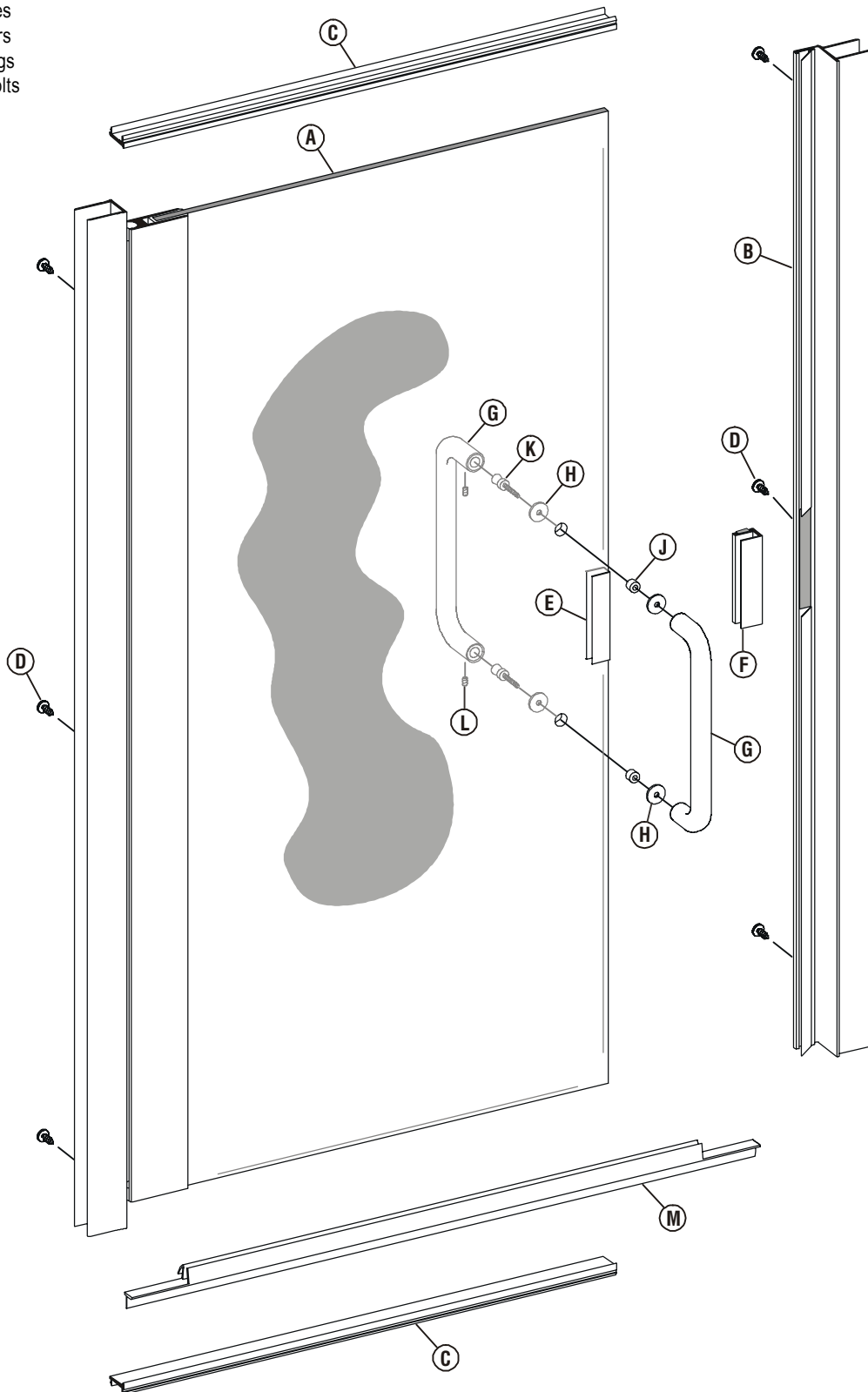

1

Press the hinge jamb/door panel assembly [*A] and strike jamb [*B] (with magnetic strip) over the wall jamb and/or framing posts. Refer to Step #1 of the STIKSTALL instruction sheet for the proper handing of the door.

Adjust the door panel assembly so there is 1/4" clearance between the strike jamb and the strike edge of the glass door panel in the closed position. Mark the location of the hinge jamb on the wall jamb (or post).

NOTE: The magnetic strip on the strike jamb must face the exterior and the door panel must open outward.

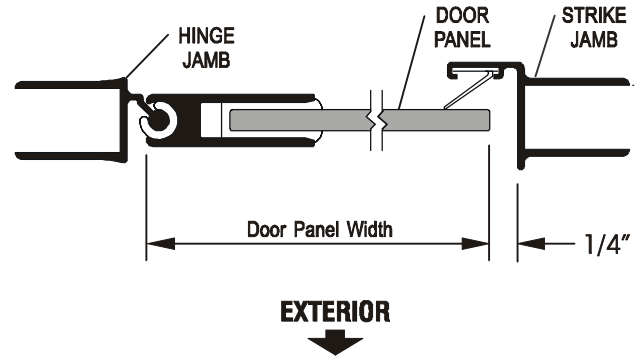
**2**

Snap both fillers [*C] into the curb and header between the hinge and strike jambs with the raised lips to the exterior. Center the curb filler between the hinge and strike jamb (use masking tape to hold in position).

NOTE: The snap-in fillers should be exactly 7/16" longer than the door panel width.

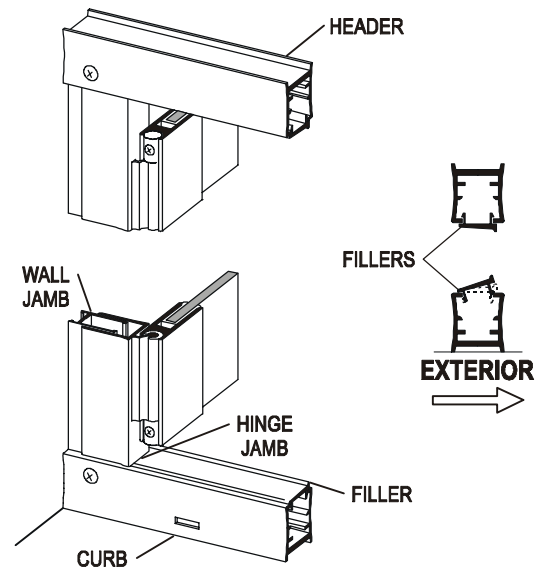
**3**

Pull the bottom end of the hinge jamb tight to the curb filler [*C] and plumb the jamb. Drill two 1/8" holes thru the hinge jamb and into the wall jamb (or post) 3/8" to 3/4" from the wall and approximately 1/4" vertically from the ends of the jamb. Drill a third hole centered between the first two and enlarge the outer holes with a 3/16" drill for clearance on the self-tapping screws. Attach the hinge jamb/door panel permanently with three #8 x 1/4" truss head screws [*D].

Slide the header filler [*C] tight against the hinge jamb. Push the strike jamb [*B] tight against the fillers top and bottom. With the hinge jamb plumb and both fillers tight between the two door jambs, the strike jamb also will be plumb and parallel to the hinge jamb. Attach the strike jamb in the same manner as the hinge jamb.

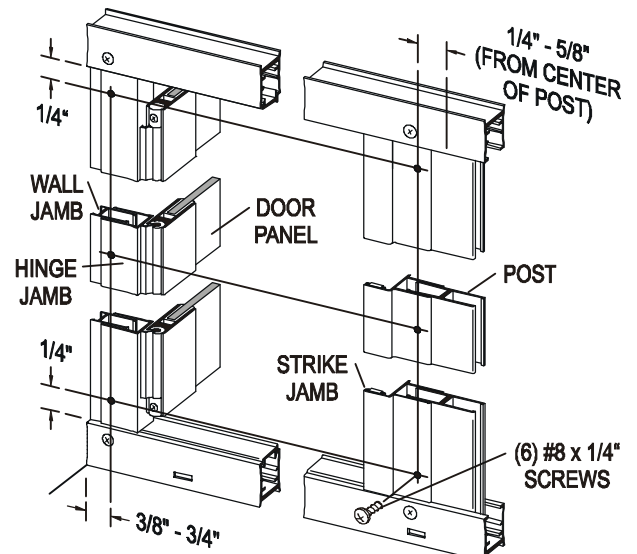

4 Slide the latch [*F] with magnet onto the strike edge of the door panel. Close the door and slide the latch up or down until the two magnetic strips are aligned. Use a pencil or masking tape to mark the location of the latch on the door.

Wrap the latch vinyl [*E] over the edge of the door glass between the marks and carefully drive the door latch onto the door panel. Spraying glass cleaner or water onto the vinyl will make assembly easier.

Close the door and check for proper operation of the magnetic catch.

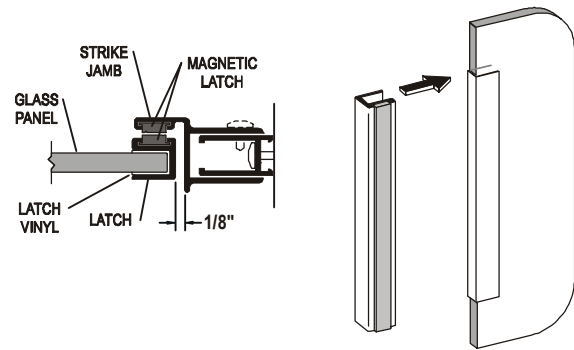

5 Determine the desired handing of the deflector [*M]. The deflector leg must go to the inside of the unit and the notch fits under the hinge rail as shown in the drawing at right. To determine the door panel width measure the distance from the edge of the hinge rail to the far edge of the glass door panel. The deflector should be cut to Door Panel Width - 7/16". Press the deflector firmly on the bottom edge of the glass as shown.

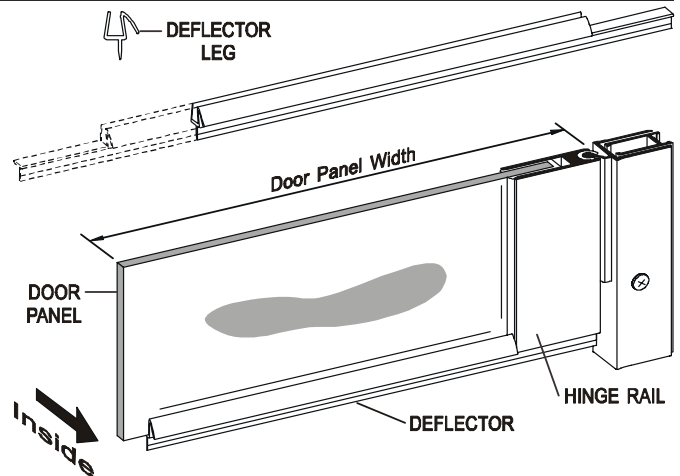

6 Locate the handle [*G] that has no Set Screws. Place a Plastic Bushing [*J] in the top handle hole then place a Plastic Washer [*H] against the glass. Place the handle without Set Screws against the Plastic Washer and insert the threaded end of the Cone Head Screw [*K] through the bushing into the threaded insert in the end of the handle and tighten. Repeat the procedure for the bottom hole. Place Plastic Washers [*H] against the opposite side of the glass and press the remaining handle [*G] over the end of the Cone Head Screw. While holding the handles firmly against the glass tighten the Set Screws [*L].

